

Chesterton Connect™ Gauge

Increase Reliability with Pressure and Temperature 24/7 Remote Monitoring

Chesterton Connect™ Gauge helps increase pump uptime by allowing you to remotely monitor pressure and temperature in localized areas of your system. Utilizing the Chesterton Connect™ Gateway, the Gauge displays the measured parameters in the Chesterton Connect™ Cloud facilitating historical data trends and 24/7 notifications when user-defined thresholds are exceeded. Combined with the Cloud, the Gauge helps provide insights to improve maintenance, drive corrective actions, and optimize equipment performance.

Applications

For use in pump suction, pump discharge and pump support systems. Suitable for measurement of liquid or gas pressure, even for difficult media such as contaminated water, steam, and mildly corrosive fluids.

DIMENSIONS

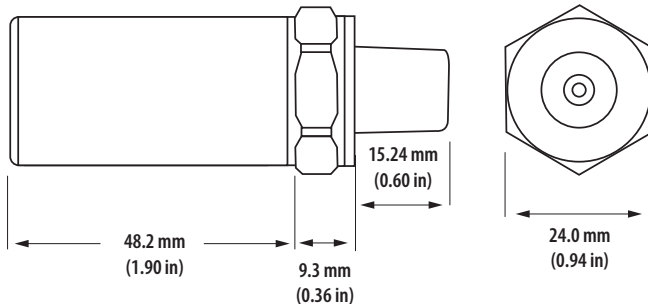

SPECIFICATIONS

Operating Parameters

| | |
|-----------------------------|---|
| Pressure | -1 bar g to 68 bar g (-14.7 psig – 1000 psig) |
| Temperature | -20°C – 85°C (-4°F – 185°F) with the CR2050 battery |
| Power | Battery CR2050 (Replaceable) |
| Fitting | 1/4" NPT |
| Material | 17-4PH and polycarbonate enclosure |
| Certifications | IP66/IP67, FCC, CE, RoHS |
| Pressure Accuracy | ±0.25% |
| Temperature Output Accuracy | ±3°C |
| Wireless | Bluetooth® 4.0 |

Software

Secured encrypted data transfer
 Easy registration through the Chesterton Connect™ App
 Measurement transfer rate: 5-minute intervals
 Seamless integration with the Chesterton Connect™ Cloud



Chesterton
Connect™

Advantages

- Early detection of process instabilities
- Improves maintenance operations
- Easy to install and configure
- Securely access your data
- Compare and correlate multiple sensors

For additional information, please contact Chesterton® engineering at connect.support@chesterton.com

Product Order Number: 418217



GLOBAL SOLUTIONS, LOCAL SERVICE

Since its founding in 1884, A.W. Chesterton Company has successfully met the critical needs of its diverse customer base. Today, as always, customers count on Chesterton solutions to increase equipment reliability, optimize energy consumption, and provide local technical support and service wherever they are in the world.

Chesterton's global capabilities include:

- Servicing plants in over 113 countries
- Global manufacturing operations
- More than 500 Service Centers and Sales Offices worldwide
- Over 1200 trained local Service Specialists and Technicians

Visit our website at
chesterton.com

Chesterton ISO certificates available on chesterton.com/corporate/iso

Chesterton Connect™ is a trademark of A.W. Chesterton Company. The Bluetooth® word mark and logos are registered trademarks owned by the Bluetooth SIG, Inc. and any use of such marks by A.W. Chesterton Company is under license.

Technical data reflects results of laboratory tests and is intended to indicate general characteristics only. A.W. Chesterton Company disclaims all warranties express or implied, including warranties of merchantability and fitness for a particular purpose. Liability, if any, is limited to product replacement only. Any images contained herein are for general illustrative or aesthetic purposes only and are not intended to convey any instructional, safety, handling or usage information or advice respecting any product or equipment. Please refer to relevant Safety Data Sheets, Product Data Sheets, and/or Product Labels for safe use, storage, handling, and disposal of products, or consult with your local Chesterton sales representative.

© 2022 A.W. Chesterton Company
® Registered trademark owned by A.W. Chesterton Company
in USA and other countries, unless otherwise noted.

Distributed by: